

# SPECIAL TOOLS

## NEW VERSION

### ⚠ CAUTION

Perform all operations on both arms.

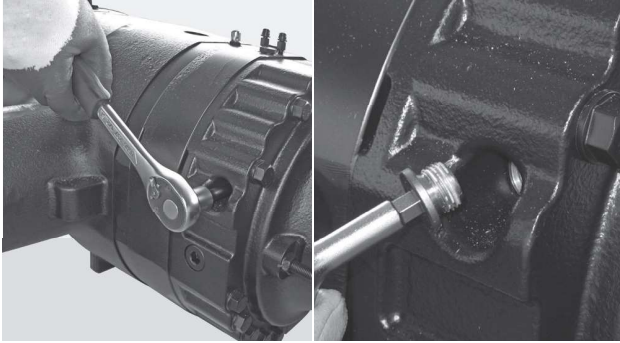

**FIGURE 1:** Remove the inspection plug.

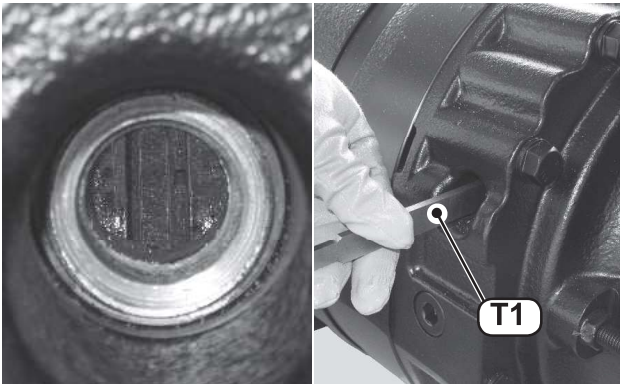

**FIGURE 2:** Apply the parking brake (or have someone hold the service brake) and with either brake applied, check the distance between discs using tool T1 (See drawing T1 p. 61). Minimum distance: 5,2 mm

### ⚠ CAUTION

Replace the braking disks and the intermediate disks on both sides if necessary. See SERVICE BRAKE AND NEGATIVE PARKING BRAKE p. 63.

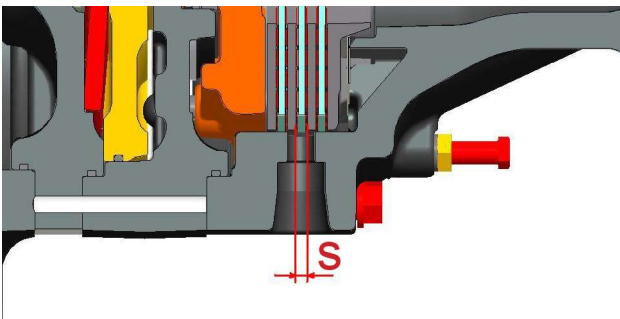

**FIGURE 3:** Checking brake distance with the T1 go / no-go gauge.



**FIGURE 4:** Install the inspection plug. Torque wrench setting for screws: 35 - 50 N·m.

SPECIAL TOOLS

T1

